

Name _____ Student ID _____

Check your (CRN) section number: **61082 8:00AM - 9:15AM** **61084 9:30AM - 10:45AM**

To get credit you must show work.

<i>Page</i>	<i>Possible Points</i>	<i>Points Scored</i>
2	10	
3	10	
4	12	
5	12	
6	8	
7	12	
8	10	
9	10	
10	10	
11	6	
Total	100	

Scaled	
---------------	--

1. The string shown is under tension from the hanging mass $m=200\text{g}$, and is $L=1.5\text{m}$ long. The linear mass density of the string is 4.1g/m .

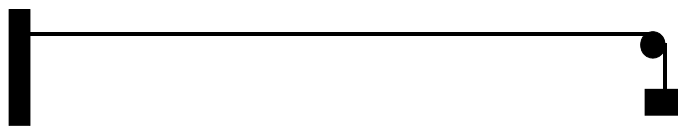

- a) (2 pts) Determine the frequency, f_2 , of the second harmonic standing wave.

$$f_2 =$$

- b) (2 pts) By what factor, f'_2/f_2 , will this frequency change if the mass, m , is doubled?

$$f'_2/f_2 =$$

2. (6 pts) A slab of insulating material has thickness $2d$ and is oriented so that its faces are parallel to the y - z -plane and given by the planes $x = d$ and $x = -d$. The y and z dimensions of the slab are very large compared to d and may be treated as essentially infinite. The slab has a uniform positive charge density ρ . Using Gauss's Law find the electric field (magnitude and direction) at all points in space.

$\mathbf{E} =$	$x < -d$
$\mathbf{E} =$	$-d < x < d$
$\mathbf{E} =$	$d < x$

3. The following interference/diffraction pattern was made with light with wavelength 500nm and distance of 10 meters from two slits.

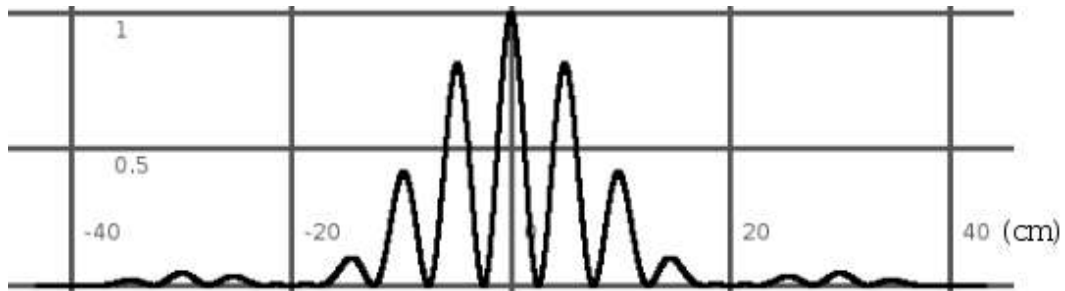

a) (3 pts) The width of the slits, a , is:

$a =$

b) (3 pts) The spacing between the slits, d , is:

$d =$

4. (4 pts) Solve for the equivalent resistance, R_{eq} , that is between the points labeled a and b , and the current, I , that flows from the ideal 10 volt battery.

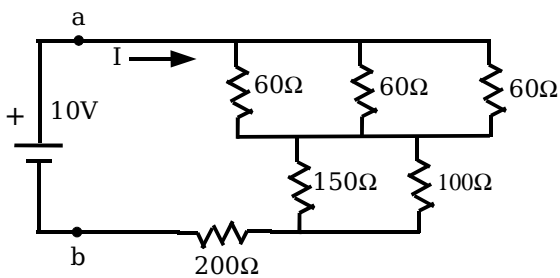

$R_{eq} =$
$I =$

5. A pipe, shown below, with length $L=1.25\text{m}$ is closed at one end and open at the other end. Use $v=344\text{ m/s}$ for the speed of sound.



a) (3 pts) Find the frequency of the fundamental, f_1 .

$f_1 =$

b) (3 pts) Find the frequency of the second overtone, f_5 .

$f_5 =$

c) (3 pts) Sketch the displacement, $y(x)$, for the air in the pipe for the second overtone when the displacement at the open end of the pipe is a positive maximum.

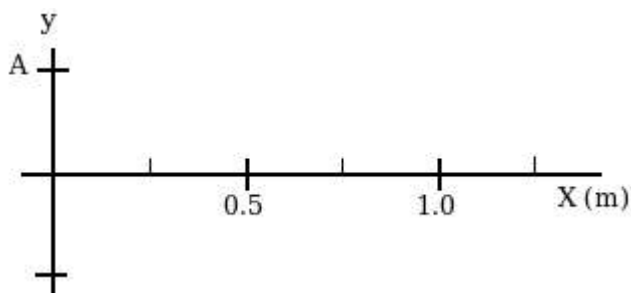

d) (3 pts) Sketch the pressure change, $p(x)$, in the pipe at the same time and conditions as in part (c).

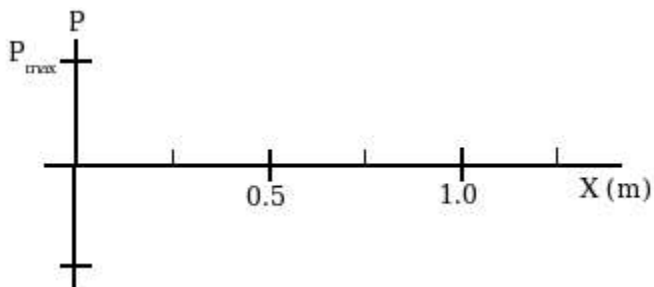

6. (6 pts) All the EMF (voltage) sources in the circuit below are ideal. Find the currents, I_1 and I_2 as they are labeled in the diagram.

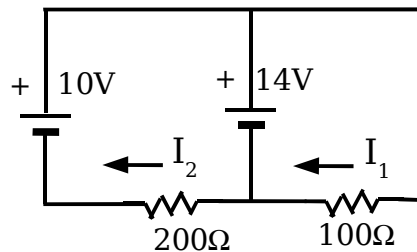

$$I_1 =$$

$$I_2 =$$

7. A small metal sphere, carrying a net charge of $q_1 = 3\mu\text{C}$, is held fixed by an insulating support. A second small metal sphere, with a net charge of $q_2 = 4\mu\text{C}$ and mass 1.5g, is headed straight at the fixed sphere, q_1 . When the spheres are 2 meters apart, the speed of q_2 toward q_1 is 10m/s.

a) (3 pts) What is the speed, v_b , of q_2 when it is 1 meter from q_1 ?

$$v_b =$$

b) (3 pts) What is the closest, x_c , q_2 gets to q_1 ?

$$x_c =$$

8. (4 pts) A circular loop wire, with radius R , carries a steady current, I_L , in a clockwise direction. A long straight wire below it carries a steady current, I_w , in the plane of the loop, at a distance of D below the center of the loop. Both wires are in the x - y plane. Find the magnetic field, \mathbf{B} (magnitude and direction), at the center of the loop.

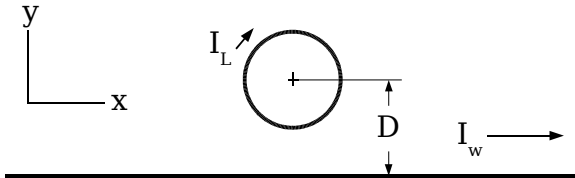

$\mathbf{B} =$

9. (4 pts) If a swimmer looks straight down into a pool of water, $n=1.33$, that is $s=2$ meters deep, how deep, $|s'|$, does the pool appear to be?

$|s'| =$

10. (6 pts) An interference pattern is produced by four equally spaced, narrow slits. Draw the phasor diagrams for the cases in which the phase difference between light from adjacent slits is $\phi = \pi/4, 3\pi/4,$ and π radians.

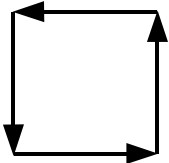
$\phi = \pi/4$	 $\phi = \pi/2$
$\phi = 3\pi/4$	$\phi = \pi$

11. (6 pts) In a physics lecture demonstration the lecturer twirls a small speaker on the end of a string in a horizontal plane over head. The signal being played to the speaker has a frequency of 300Hz. The source of the sound is turning in a circle with a radius, $R = 1.5$ meters, and is spinning at a steady rate with 2 revolutions per second. The speed of sound is 340 m/s. What is the highest, f_H , and lowest, f_L frequency heard by the students listening with their ears in the plane of the rotating speaker?

$f_H =$
$f_L =$

12. A lens, located at $x = 10\text{cm}$, produces a 0.5cm high, erect image at $x = 5\text{cm}$, as shown in the sketch below. An object is located at $x = 0\text{cm}$. The light travels from left to right in this figure.

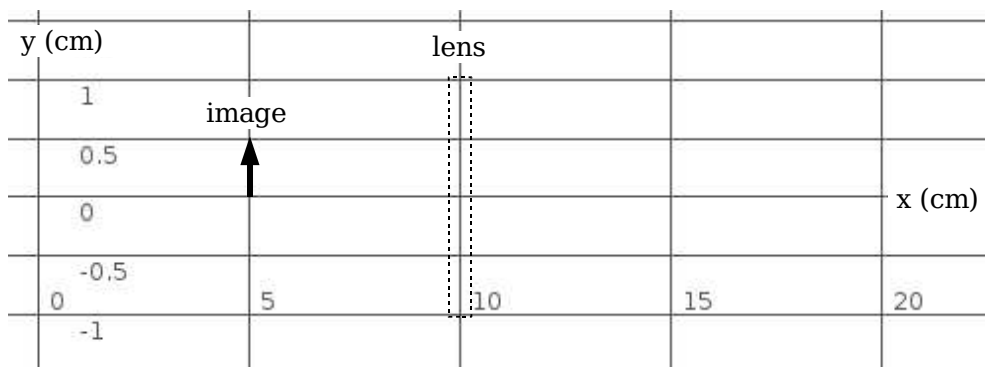

a) (3 pts) What is the size, y , of the object?

$y =$

c) (1 pt) Is the image real or virtual?

(circle one) real virtual

b) (3 pts) What is the focal length, f , of the lens?

$f =$

c) (3 pts) Draw the three principal rays for the image on the grid above.

13. A woman must wear "driving" glasses which have a lens with a focal length of -200cm and "reading" glasses with a focal length of $+50\text{cm}$.

a) (3 pts) What is value of her far point, FP?

FP =

b) (3 pts) Assuming that her corrected near point is 25cm , what is the value of her near point, NP, without glasses?

NP =

14. (4 pts) A ray of light is refracted at a plane interface between two different mediums. The index of refraction for medium 2 is $n_2=1.4$. What is the speed of light in medium 1, v_1 ?

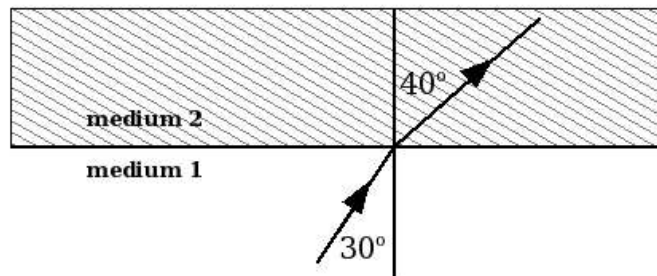

$v_1 =$

15. An enterprising 2306 student wants to accurately measure the thickness of a hair. She has two flat plates 10cm long and a 520nm source of light. She stacks the plates together in air with the hair between the plates at one end and views the light pattern on the plates from above.

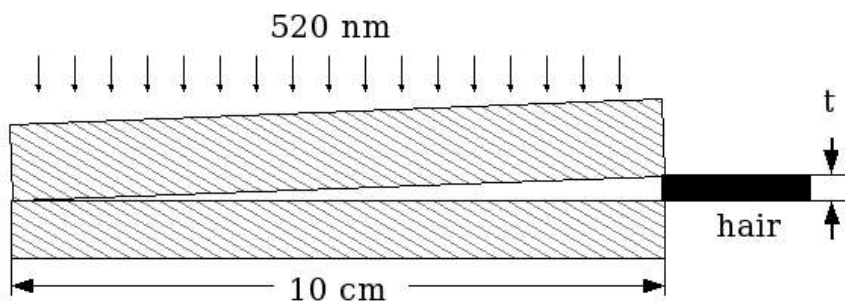

a) (2 pts) Is there a dark or bright fringe at the end of the plates opposite the hair?

(circle one) **Dark** **Bright**

b) (3 pts) She notes that there is a dark fringe next to the edge of the hair. She counts 32 dark fringes along the plates from the edge of the tissue to the end where the plates touch. How thick, t , is the hair?

$t =$

16. (5 pts) A photographer wants to take a picture of a brick building that is 4000m away. The spacing between layers of bricks is 8cm, and he wants the individual mortar lines to be visible on his photograph. Assuming that the film does not limit his resolution, and the wavelength of the ambient light is 500 nm, what is the minimum diameter, D , of his lens (and aperture) needed to do this?

$D =$

17. (6 pts) A factory uses a few electric motors that have a net inductive and resistive load, Z . The current to all the electric motors has a 30° phase lag between the current and the voltage (voltage leads the current by 30°). The amplitude of the AC current to all the motors is $I_0=210\text{A}$. The amplitude of the applied voltage is $V_{\text{max}}=294\text{V}$ at 60Hz AC. Find the motors' equivalent impedance, Z , the capacitance, C , needed to put the line current in phase with the applied voltage, and I , the amplitude of the current in the line feeding the now "balanced" load.

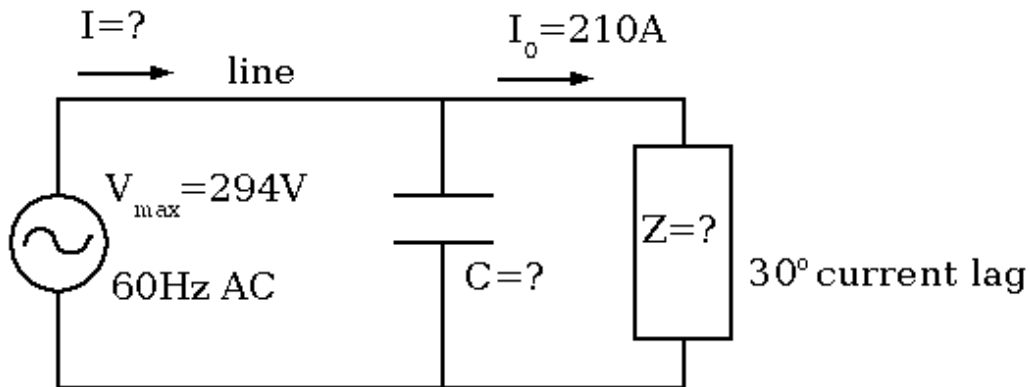

$Z =$
$C =$
$I =$