

Name _____

This is very similar to your final exam. I added some extra hints and references on the material that has not been covered yet in the course. Most of it has been covered, so don't wait to "have at it". Non-exam-like comments are in this (reddish) color and font.

Page	Possible Points	Points Scored
2	12	
3	12	
4	12	
5	12	
6	10	
7	12	
8	10	
9	10	
10	10	
Total	100	

1. The string shown is under tension from the hanging mass $m=250\text{g}$, and is $L=1.2\text{m}$ long. The linear mass density of the string is 5.1g/m .



- a) (2 pts) Determine the frequency, f_1 , of the first harmonic standing wave.

$f_1 =$

- b) (2 pts) By what factor, f'_1/f_1 , will this frequency change if the mass, m , is doubled?

$f'_1/f_1 =$

2. (8 pts) A slab of insulating material has thickness $2d$ and is oriented so that its faces are parallel to the y - z -plane and given by the planes $x = d$ and $x = -d$. The y and z dimensions of the slab are very large compared to d and may be treated as essentially infinite. The slab has a uniform positive charge density ρ . Using Gauss's Law find the electric field (magnitude and direction) at all points in space.

$\mathbf{E} =$	$x < -d$
$\mathbf{E} =$	$-d < x < d$
$\mathbf{E} =$	$d < x$

3. The related text for this is from section 36.4 which we'll cover in the last lecture. Try it now, it's not much of a stretch.

The following interference/diffraction pattern was made with light with wavelength 600nm and distance of 10 meters from two slits.

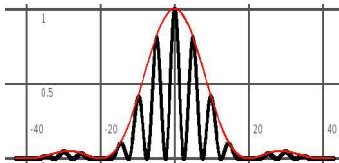
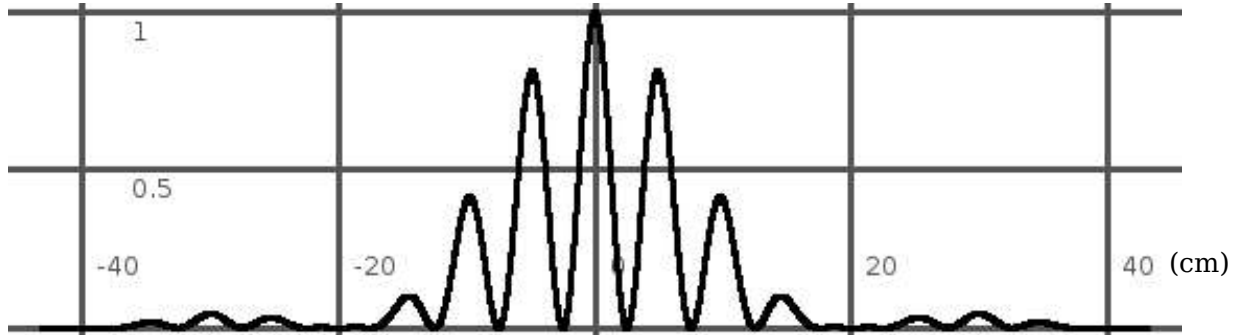

The diffraction and interference patterns are multiplied times each other. So we have an interference pattern inside a diffraction envelope (in red in the image to the left).

a) (3 pts) Question about the diffraction envelope (just ignore the two slit interference fast wiggles, black, for this part): The width of the slits, a , is:

a =

b) (3 pts) Question about the two slit interference pattern. So ignore the diffraction envelope: The spacing between the slits, d , is:

d =

4. (6 pts) Solve for the equivalent resistance, R_{eq} , that is between the points labeled a and b, and the current, I , that flows from the ideal 12 volt battery.

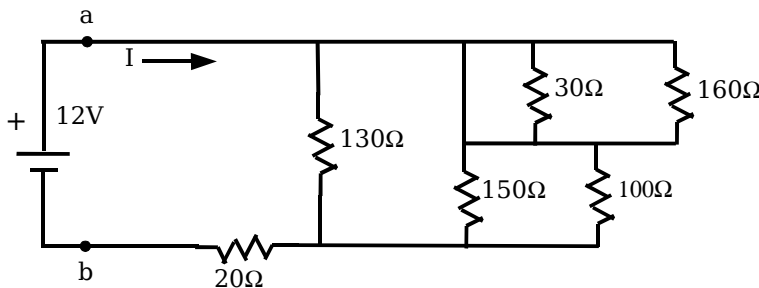

$R_{eq} =$
$I =$

5. A pipe, shown below, with length $L=1.0\text{m}$ is open at both ends. Use $v=344\text{ m/s}$ for the speed of sound.



a) (3 pts) Find the frequency of the fundamental, f_1 .

$f_1 =$

b) (3 pts) Find the frequency of the second harmonic, f_2 .

$f_2 =$

c) (3 pts) Sketch the displacement, $y(x)$, for the air in the pipe for the second harmonic when the displacement at the left end of the pipe is a positive maximum.

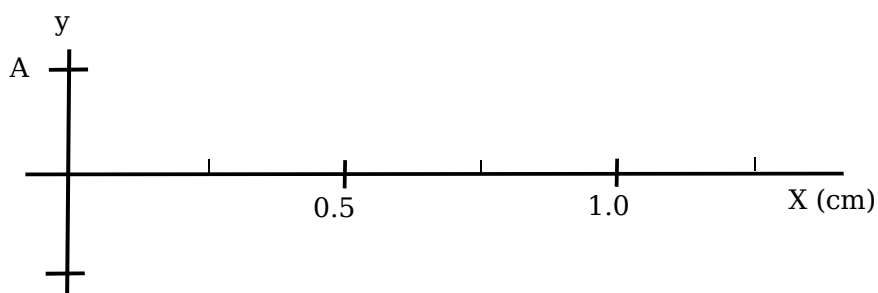

d) (3 pts) Sketch the pressure change, $p(x)$, in the pipe at the same time and conditions as in part (c).

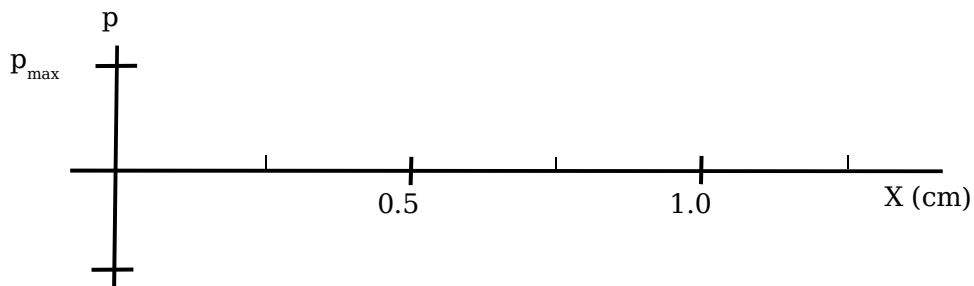

6. (6 pts) All the EMF (voltage) sources in the circuit below are ideal. Find the currents, I_1 , I_2 and I_3 as they are labeled in the diagram.

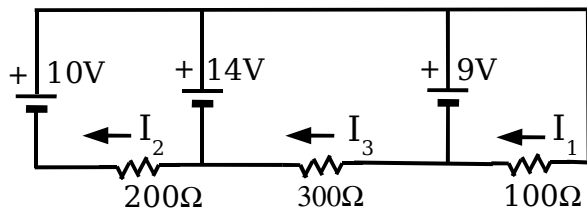

$$I_1 =$$

$$I_2 =$$

$$I_3 =$$

7. (6 pts) A small metal sphere, carrying a net charge of $q_1 = 2\mu\text{C}$, is held fixed by an insulating support. A second small metal sphere, with a net charge of $q_2 = 7\mu\text{C}$ and mass 2.5g , is headed straight at the fixed sphere, q_1 . When the spheres are 4 meters apart, the speed of q_2 toward q_1 is 18.6m/s . What is the closest, x_c , q_2 gets to q_1 ?

$$x_c =$$

8. (5 pts) See example 34.7. A fish looks up out of the water at a fly that is hovering 10 cm above the water. How high does the fly look to the fish? Use $n_{\text{water}}=1.33$.

$s' =$

9. (5 pts) The loop shown carries a current of I in the direction shown. Find the magnetic field, \mathbf{B} , at the origin. Express your answer in terms of I , and a .

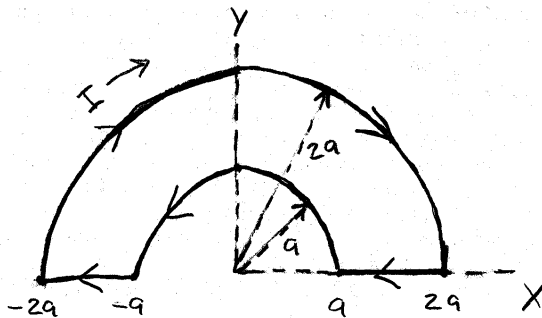

$B_x =$
$B_y =$
$B_z =$

10. (12 pts) From section 36.4. An interference pattern is produced by six equally spaced, narrow slits. Draw the phasor diagrams for the cases in which the phase difference between light from adjacent slits is $\phi = \pi/3$, $2\pi/3$, and π radians.

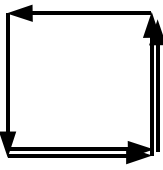
$\phi = \pi/3$	 <p>A phasor diagram for $\phi = \pi/2$ showing six vectors of equal length arranged in a regular hexagon. The vectors are drawn from a common origin, and their tips form a closed hexagonal loop, indicating that the resultant phasor is zero.</p> $\phi = \pi/2$
----------------	--

$\phi = 2\pi/3$	$\phi = \pi$
-----------------	--------------

11. From section 34.4. A lens, located at $x = 10\text{cm}$, produces a 1.0cm high, inverted image at $x=20\text{cm}$, as shown in the sketch below. An object is located at $x=5\text{cm}$. The light travels from left to right in this figure.

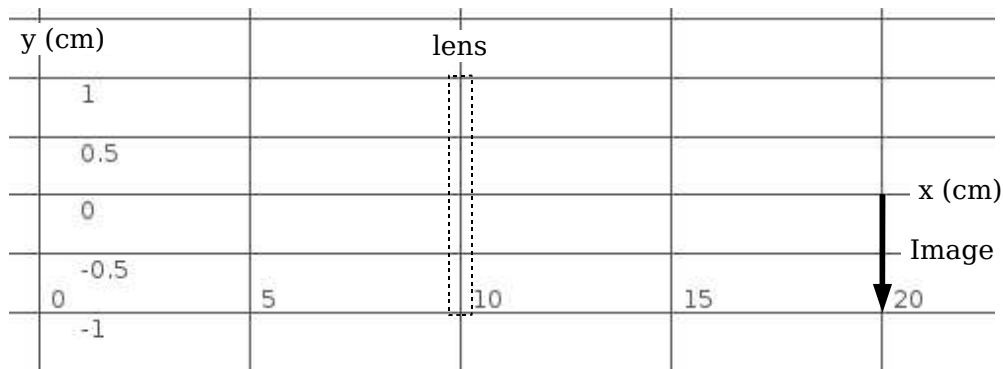

a) (4 pts) What is the size, y , and orientation (erect or inverted) of the object?

$y =$
(circle one) erect inverted

b) (3 pts) What is the focal length, f , of the lens?

$f =$

c) (3 pts) Draw the three principal rays for the image on the the grid above.

12. From section 34.6. A woman must wear reading glasses. Her near point is 50 cm. She wishes to read with things from a distance of 25 cm with her reading glasses.

a) (5 pts) How strong do her glasses need to be?

diopeters

13. (5 pts) A ray of light is refracted at a plane interface between two different mediums. The angle of the incident ray is 30° . The index of refraction for medium 1 is $n_1=1.8$. The index of refraction for medium 2 is $n_2=1.4$. What is the angle of the refracted ray, θ_2 , from the normal?

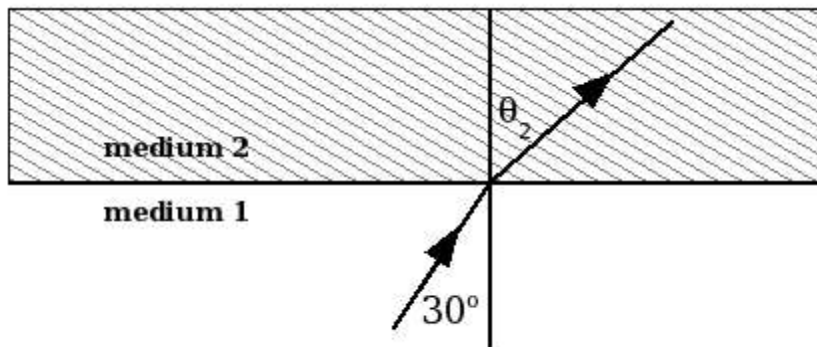

$\theta_2 =$

14. (5 pts) Two slides shown light from the top with monochromatic light with wavelength 500nm . There is no space between the slides at one edge and a $7.5\ \mu\text{m}$ gap at the other edge. There is air between the slides. How many dark fringes will be seen?

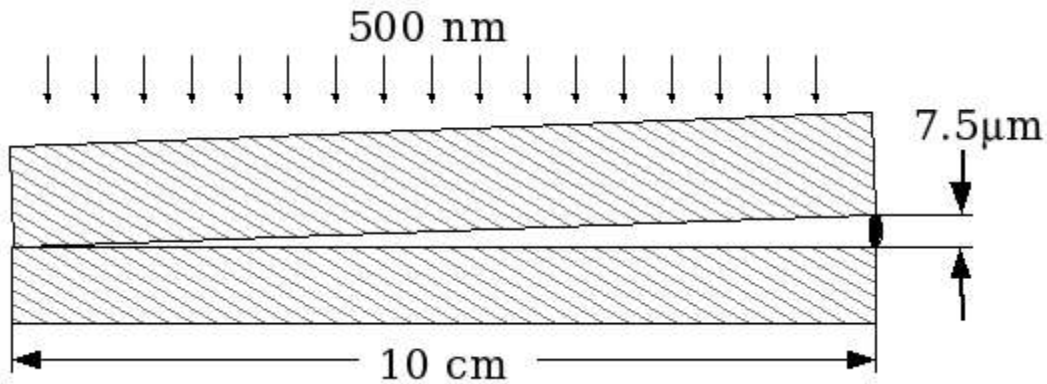

$n =$

15. (5 pts) From section 36.7. Two satellites are at an altitude of 1400 km are separated by 20 km . If they broadcast 3.6 cm microwaves, what minimum receiving dish diameter, D , is needed to resolve the two transmissions?

$D =$